

FEATURES

- CoreHW CHW1010-ANT2 antenna module utilized for AoA and AoD direction finding systems
- Operating frequency range: 2400-2483 MHz
- CoreHW CHW1010 SP16T AoA and AoD antenna switch
- Connectors for radio frequency signals and CoreHW CHW1010 SP16T GPIO control signals
- Sixteen patch antenna elements
- Low cost 4-layer PCB stack-up structure
- Optimized phase balance between antenna chains
- Firmware support and antenna models available
- PCB dimensions: 150mm x 150mm

APPLICATIONS

- *Asset tracking in factories, offices, logistics etc.*
- *Access control*
- *People tracking*
- *Wayfinding*
- *Point-of-interest services*
- *Proximity marketing*
- *Shopping guidance and assistance*
- *Equipment and facilities utilization*
- *Consumer behavior analysis*
- *Security services*
- *Item finding*

www.corehw.com

GENERAL DESCRIPTION

CoreHW CHW1010-ANT2 is an antenna module consisting of sixteen patch antenna elements. The antenna array PCB is intended for direction and positioning system solution providers.

CHW1010-ANT2 module incorporates the CoreHW CHW1010 SP16T antenna switch, which can be utilized to control and sample RF signals for Bluetooth® AoA and AoD technology. The device comprises of very low phase mismatch antenna switch array which enables real high accuracy positioning.

CHW1010-ANT2 antenna module enables system solutions which are insensitive to multipath signal and has outstanding position accuracy down to 10cm level.

CoreHW offers an AoA evaluation kit with CoreHW firmware and Windows PC positioning engine software with user interface (GUI). The kit contains four patch antenna array-based locators. The evaluation kit can be used for laboratory tests and PoC testing in real use case scenarios.

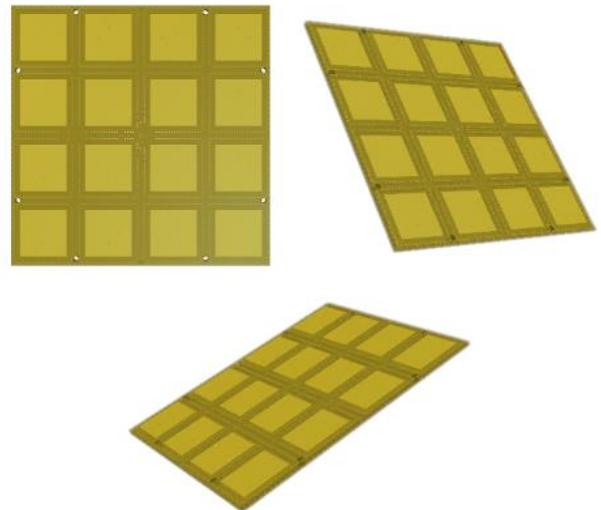

CHW1010-ANT2 PCB CONNECTORS AND SIGNAL PINS

Table 1. Connector types

RF connector	GPIO connector
MCRF coaxial 50 Ohms	FPC vert 10pos, pitch 1mm

Table 2. GPIO pin contacts

Pin	Purpose	Description
1	VBAT	Supply voltage (3V nominal)
2	Unused	Unused
3	GND	GND
4	GND	GND
5	D1	ANT_SELO
6	D3	ANT_SEL2
7	D2	ANT_SEL1
8	D4	ANT_SEL3
9	D0	Digital control input
10	EN	Chip enable

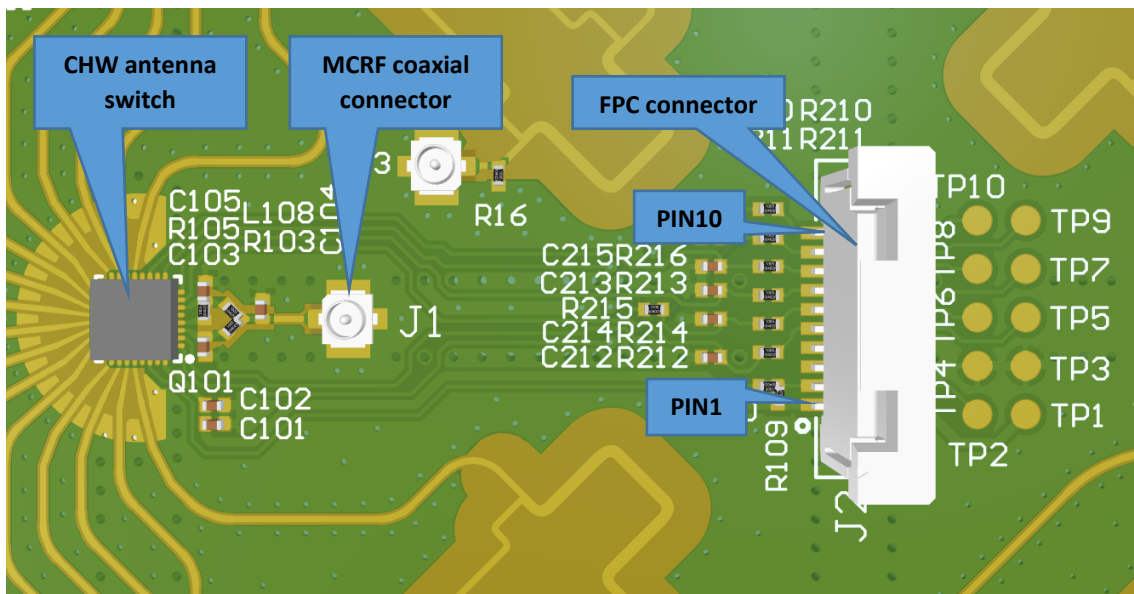

Technical Data

CHW1010-ANT2-1.0

DIMENSIONS

PCB thickness: 3.6 mm

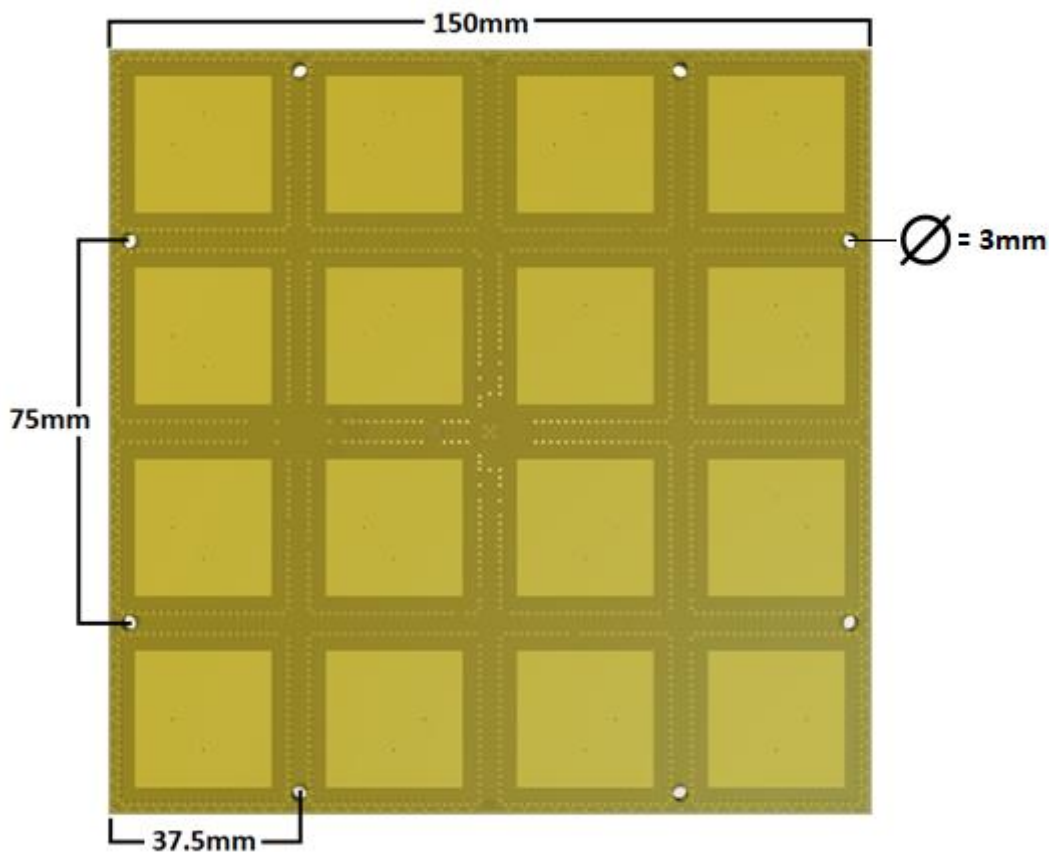

CONTACT DETAILS

Sales

sales@corehw.com

Technical support

product.support@corehw.com

CoreHW Oy
Visiokatu 1
33720 Tampere
Finland

www.corehw.com

Disclaimer

The contents of this document are subject to change without prior notice. CoreHW makes no representation or warranty of any nature whatsoever (neither expressed nor implied) with respect to the matters addressed in this document, including but not limited to warranties of merchantability or fitness for a particular purpose, interpretability or interoperability or, against infringement of third party intellectual property rights, and in no event shall CoreHW be liable to any party for any direct, indirect, incidental and or consequential damages and or loss whatsoever (including but not limited to monetary losses or loss of data), that might arise from the use of this document or the information in it.

© Copyright CoreHW. All rights reserved.